



Safety Speed Cut Mfg.

Product Guide
saws, knives and accessories
designed for your industry

*"Our Safety Speed Cut
Vertical Panel Saws are the
most reliable, essential and
flexible tools we have."
G.M. Humpries – Stauton, RI*

C4

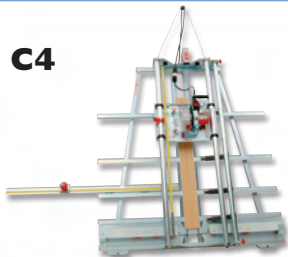

H5

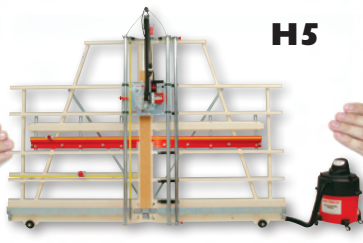

STS24





LOOK who uses our products

Sign-A-Rama, Fast Signs, Signs By Tomorrow,
Signs Now, Home Depot, Lowes and many more...

*"Our shop space is small.
With the addition of our Safety
Speed Cut Panel Saw, we now
have large shop production."
Curt Abrecht – Allenwood, NJ*



Why Safety Speed Cut?

Cut's these products & more!



For over 50 years Safety Speed Cut saws have allowed signmakers and graphic production shops to cut a large variety of sign materials safely, easily and accurately. Now you can customize your machine to get maximum productivity with our unique sign saw package, knife kit and accessories. With our intense focus on providing our customers with outstanding products, value and customer service you can be extremely confident in your decision to buy our products.

Safety Speed Cut

all these great features...

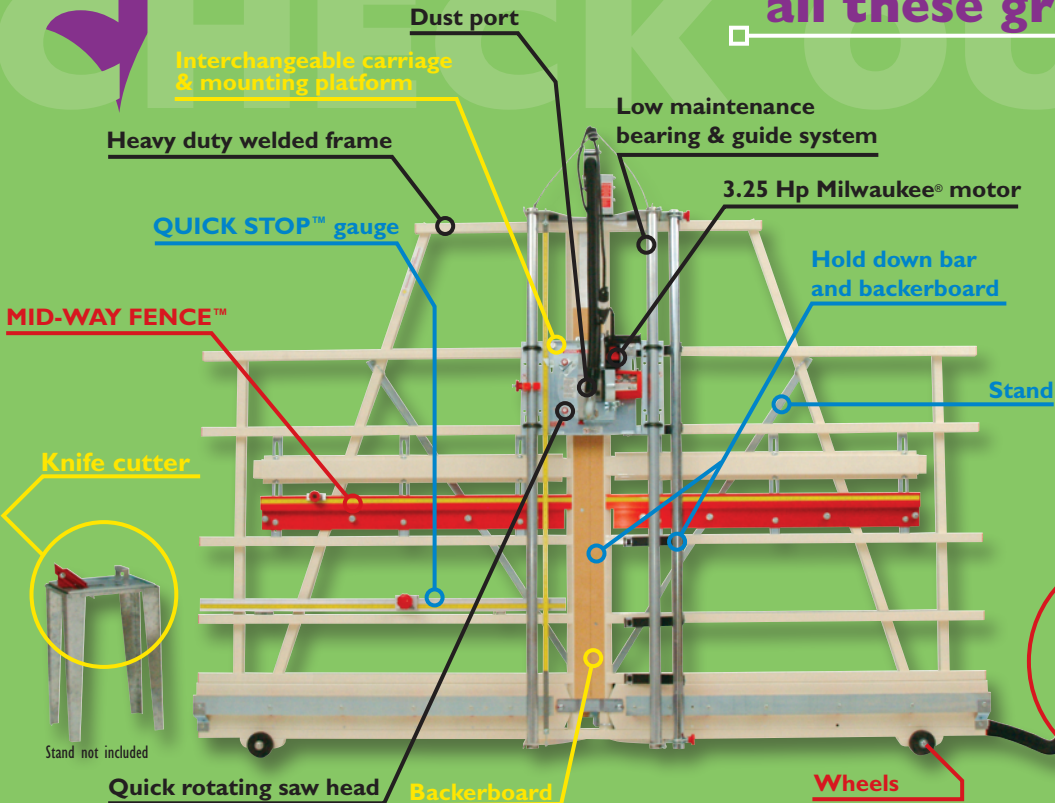

SignSaw Package

- * Hold down bar
- * Backerboard
- * QUICK STOP™ gauge
- * Stand
- * Blade

Knife Kit

- * Knife cutter
- * Backerboard
- * Interchangeable carriage & mounting platform

Other Accessories

- * MID-WAY FENCE™
- * Wheels
- * Dust collector
- * See pg.6 for more!

Dust collector



Standard components in black

Panel Saws

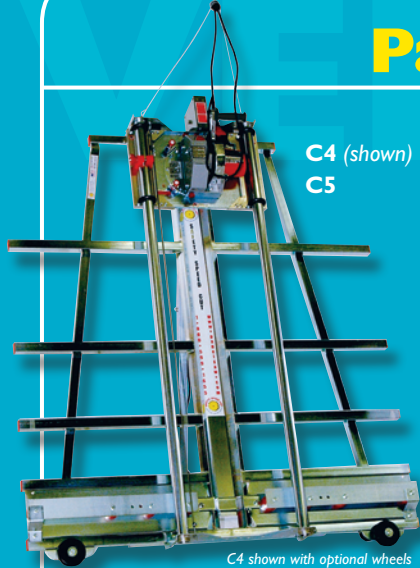

C4 shown with optional wheels

C4 (shown)
C5

Efficiency,
versatility and
cost savings all in
ONE machine.

Pick Your Saw!

Our economical panel saws give you the ability to cut materials fast and accurately at a low cost per cut. Just add our sign saw package, knife kit or other accessories to increase the efficiency and versatility of your saw... It's that simple!

“Dollar for dollar, our Safety Speed Cut Vertical Panel Saw is the best investment we have made for our shop.”
Mickey Boatwright – Orlando, FL

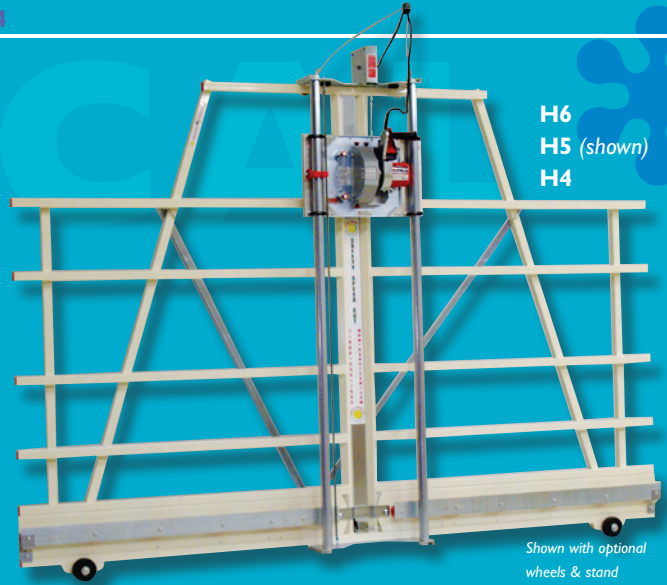

H6
H5 (shown)
H4

Shown with optional wheels & stand

Specifications	C4	C5	H4	H5	H6
Frame width	5'	5'	10'	10'	10'
Maximum vertical cut	50"	64"	50"	64"	74"
Maximum horizontal cut	Unlimited				
Maximum cut thickness	1 3/4"				
Cutting accuracy	1/32"				
Standard power	3.25 Hp, 15 amp, 120V				
Blade diameter	8"				



Hold down bar

Keeps thin and flexible materials firmly against the machine frame for safe and accurate cutting.



QUICK STOP™ Gauge

Promotes quick set up for repeat cuts. The QUICK STOP™ gauge comes with a 5' long extrusion with a recessed ruler and stop block.

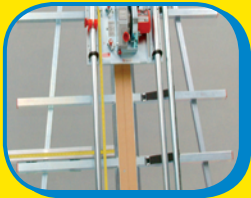

Backerboard

Helps support cutting thin and flexible material while using either the saw or the knife cutter. Also shows where the cut will begin.



Stand

Allows the machine to free stand anywhere in your shop. The C4/C5 stand folds for easy storage and transportation while the H-series are fixed.

Sign Saw Package

Our sign saw package includes accessories designed for and proven by industry experts. This package will maximize the productivity and efficiency of your panel saw resulting in higher profits for your shop!



Signmakers blade

A good quality general-purpose blade for cutting a wide range of plastic materials.

“Our Safety Speed Cut Saw, as far as I’m concerned, is the best saw and easiest to use on the market today. It is safe to use and very reasonably priced.” Jeremy Kaul – Bismark, ND

Knife Kit & More...

Available for the C4, C5, H4, H5 and H6

We know from experience that the right **ACCESSORIES** can dramatically increase productivity!

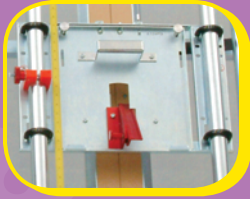

Knife kit

Allows for dust free cutting of foamcore, coroplast, gatorboard & anything else that can be cut with a utility knife. The kit includes a quick change knife and saw mounting platform, interchangeable carriage and a backerboard.



MID-WAY™ fence

Reduces back fatigue while cutting quantities of small panels on your machine by bringing them to waist height. The system uses removable supports on both sides of the frame and includes a stop block and rulers.



Extensions & wheels

The lower extensions add 20" to each side of the material rollers while the upper extensions extend the upper square tubing of your frame by 20". The wheels permit the machine to be moved easily in an upright position.



Automater

Activates your vacuum when your panel saw is started. Increases shop productivity by guaranteeing your vacuum starts every time you make a cut.



Dust collection

Effectively removes dust particles maintaining a cleaner and safer workplace. You can choose the dust kit that connects your machine to an existing collector or the complete system with a 6 Hp vacuum.



Saw blades

We offer a variety of high quality saw blades. These blades will give your Panel Saw high-performance cutting capability to meet your sign and display making needs. Blades are also readily available on the market.

Table Saw

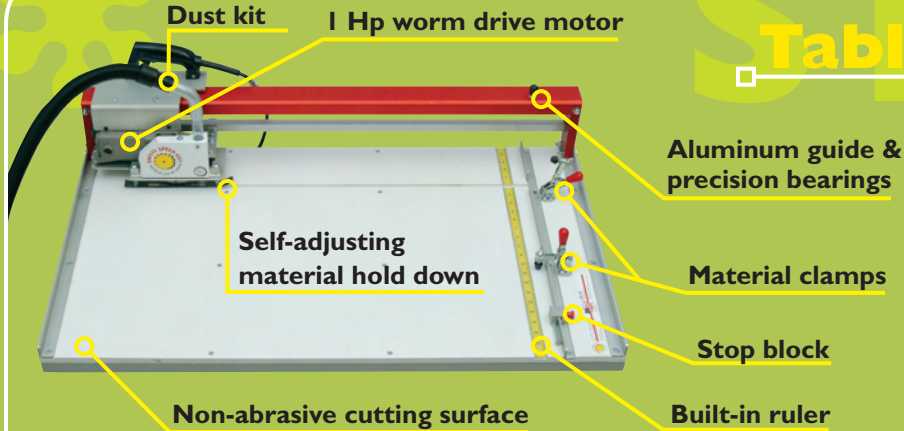

The STS24 tablesaw is the ideal shop tool for accurate, consistent sizing of smaller plastic, wood, aluminum and composite panels. Designed to handle pieces up to 24" wide, the STS24 provides an easy way to cut hard to hold and flexible materials that are difficult to size.



Specifications	STS24
Maximum cut	24"
Maximum cut thickness	1/4"
Cutting accuracy	+/- 0.010"
Standard power	1 Hp
Blade diameter	4 1/2"

Wall Mounting Kit - Easy as 1-2-3



- Free up valuable space in your shop by attaching the STS24 to a wall. The kit includes a spring loaded counterbalance and mounting brackets.
- Step 1** – Mount spring loaded counter balance to table saw
- Step 2** – Attach brackets to wall
- Step 3** – Secure table saw to brackets

Footprint info

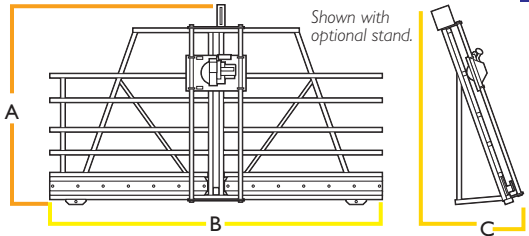

"My Safety Speed Cut machine is the best thing since sliced bread. It cut our production time by over 65%."

Gary Eubanks – Carrollton, TX



13943 Lincoln Street NE
Ham Lake, MN 55304
www.signsaw.com
800.599.1647

Saw	Dim. A	Dim. B	Dim. C	Weight
C4	75"	60"	36"	189 lbs.
C5	90"	60"	36"	219 lbs.
H4	75"	120"	36"	244 lbs.
H5	90"	120"	36"	298 lbs.
H6	98½"	120"	36"	359 lbs.

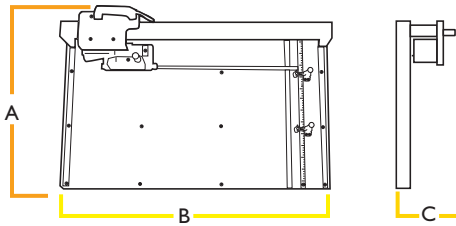

Saw	Dim. A	Dim. B	Dim. C	Weight
STS24	23½"	40"	11½"	76 lbs.

Guaranteed straight and square from the factory!